

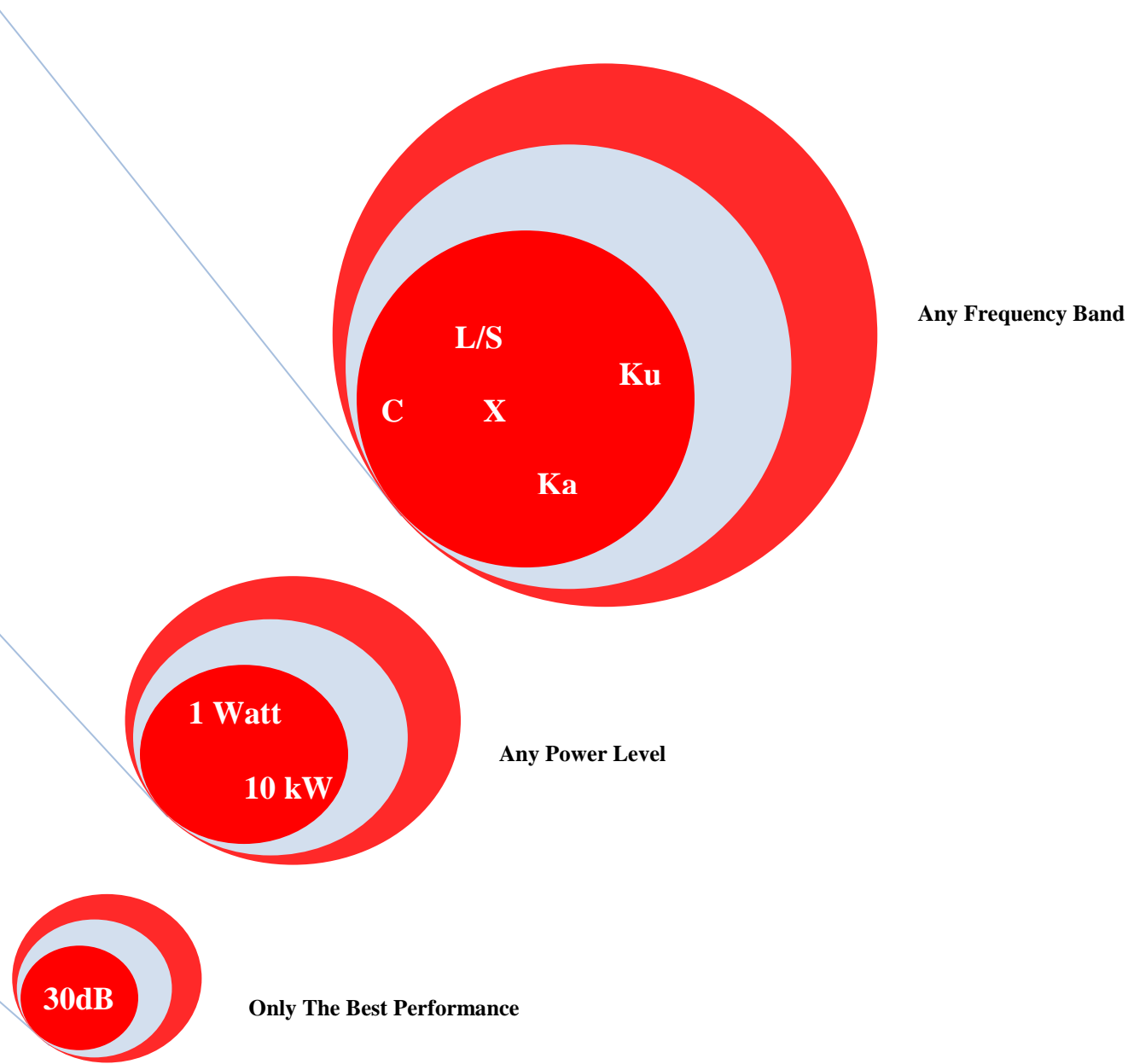

Unique Broadband Systems Ltd.

400 Watt, Ku-Band, Indoor Power Amplifier



Product Features

- Solid State Linear Design
- Excellent output VSWR protection
- Local & Remote Gain Adjustment
- ALC Mode of Operation
- Direct Power Settings in dBm/watts
- Temperature Gain Compensation
- Sample monitoring port (front or rear)
- Built-in HPA controller with POE interface for controller independent power
- Built-in Waveguide Switch Control for up to 3 Switches



Frequency Bands

Regular Band of operation: 14-14.5 GHz
(Extended) Ku-Band: 13.75 GHz – 14.5 GHz
Also 12.75-13.25MHz sub-band available

Product Description

Unique Broadband Systems' DMPA4000KUB is an indoor 400W Solid State Power Amplifier (SSPA) built using GaN technology. This ultra compact 3RU amplifier is composed of two SSPA bricks, a forced air cooling system and a local front panel control with user friendly interface. In addition, the built-in system controller provides the ability of serial interfacing using RS 485, Ethernet and CAN-bus for remote monitoring and control as well as amplifier combining.

An internal voltage variable attenuator allows 15 dB of continuous gain adjustment. A digital temperature compensation system regulates the RF signal level within a +/-1.0 dB window over the entire operating temperature range. Rear access precision face-shifter is included for multiple amplifier combining. Every GaN output transistor is fully protected against potentially harmful reflected power due to antenna mismatches.

This amplifier is designed for rack mounting in protected environment. Excellent performance, high efficiency and long term MTBF are achieved through using superior mechanical and thermal designs. Our matured manufacturing process ensures the highest quality of all physical components and optimized performance to meet the most rigorous industry standards and clients' demands. At the same time, our ISO 9001 Quality assurance program leads to the superior performance and reliability in the long-run.

(Specifications are subject to change without notice)

400 Watt, Ku-Band, Indoor Power Amplifier

Product Specifications

Electrical Specifications		
Operating Frequency		13750 MHz – 14500 MHz
Output Power	P-Saturated	400 Watt (56 dBm)
	P-Linear (IM3 \leq -25dBc)	160Watt (52 dBm)
Gain Parameters	Full Band Flatness (power gain) ¹	\pm 1.0 dB
	Gain	54 dB
	Small Signal Gain	58 dB min
	Per 40 MHz	\pm 0.3 dB
	Over Temperature (0°C to +55°C)	\pm 1.0 dB
Internal Attenuator	Adjustment Range	Up to 15 dB with 0.1 resolution
3rd Order Intermodulation (IM3)	Two tone, 5 MHz apart, @ rated P-Linear	-25 dBc
AM/PM Conversion	@ rated P-Linear	3.5 %/dB max.
Spurious	@ rated P-Linear	-60 dBc max.
2nd Order Harmonics	@ rated P-Linear	-50 dBc max.
ALC Range		+2 to +15 dBm
Noise Power Density	RX-Band	-150 dBW/4 KHz
	TX-Band	-75 dBW/4 KHz
Group Delay (per 40 MHz segments)	Linear	0.01 ns/MHz
	Parabolic	0.003 ns/MHz ²
	Ripple	1.0 ns p-p
Residual AM Noise	0 - 10 KHz	-45 dBc
	10 KHz - 500 KHz	-20 dBc
	500 KHz - 1 MHz	-80 dBc
RMS RF Power Detector	Range	30 dB
	Accuracy	\pm 0.5
VSWR	Input	1.30:1
	Output	1.30:1
Noise Figure		10dB max.
Mechanical Parameters		
Size		3RU
Input RF Connector		N-type Female
Output RF Connector		WR75G
Output RF Sample Port		N type Female
RS 232		D-Sub 9S
RS 485		D-Sub 9S
Ethernet		RJ45
Cooling		Built-in forced-air cooling
Environmental Specifications		
Operating Temperature		0°C to +50°C
Storage Temperature		-40°C to +85°C
Humidity		+5% to 95% non-Condensing
Altitude		3000M above sea level
Power Requirements		
Power Supply		24V DC / 12V DC
AC Power Consumption @ 400 W		2500 W

(Specifications are subject to change without notice)

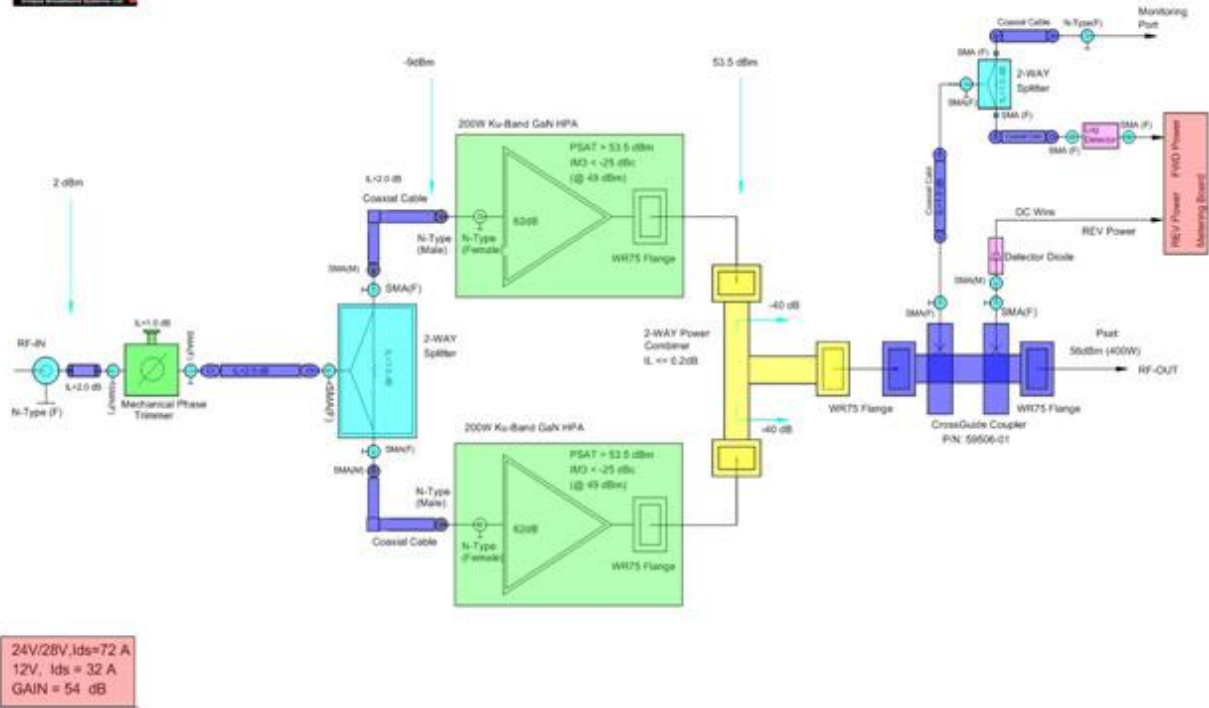

Block Diagram 1

(Specifications are subject to change without notice)

Outline Drawings

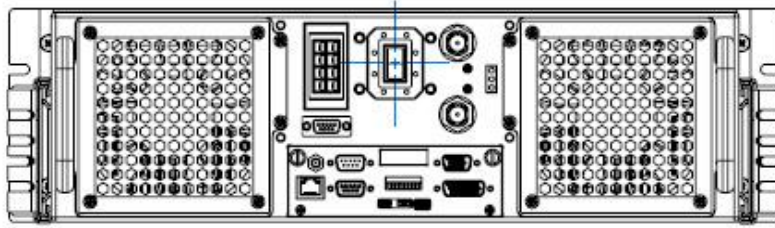

Picture 1: Ku Band 200/400W Indoor Amplifier Rear View

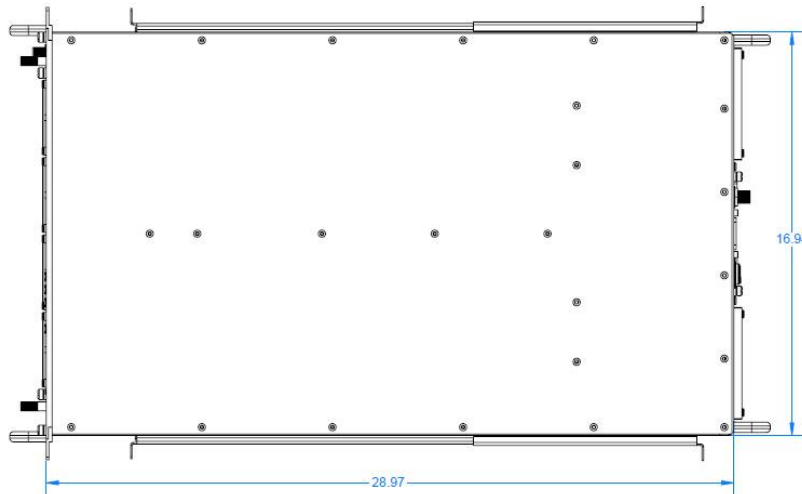

Picture 2: Ku Band 200/400W Indoor Amplifier Top View

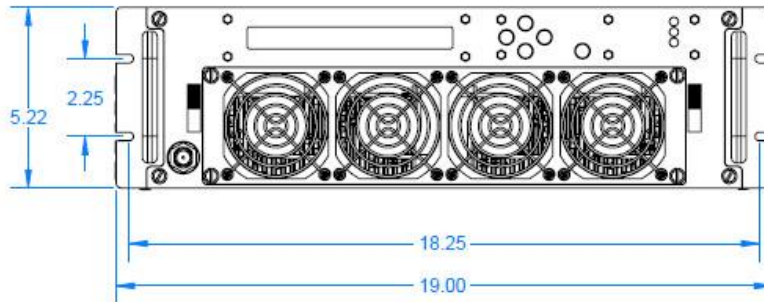

Picture 3: Ku Band 200/400W Indoor Amplifier Front View

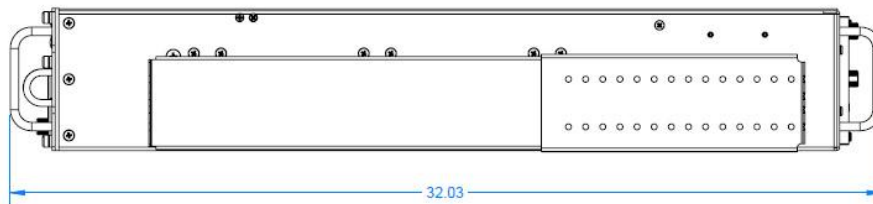

Picture 4: Ku Band 200/400W Indoor Amplifier Side View

(Specifications are subject to change without notice)



Part Number Configuration

