

## WR90 Arc Detector

### Typical Application

- SATCOM
- Broadcast
- Radars
- Monitoring and control of visible arcs inside High-Power Waveguide Systems

### Product Features

- Wide spectral responsivity
- Fast time response
- Optics withstanding high temperature inside waveguide
- High electromagnetic coupling between waveguide and detectors' cavity

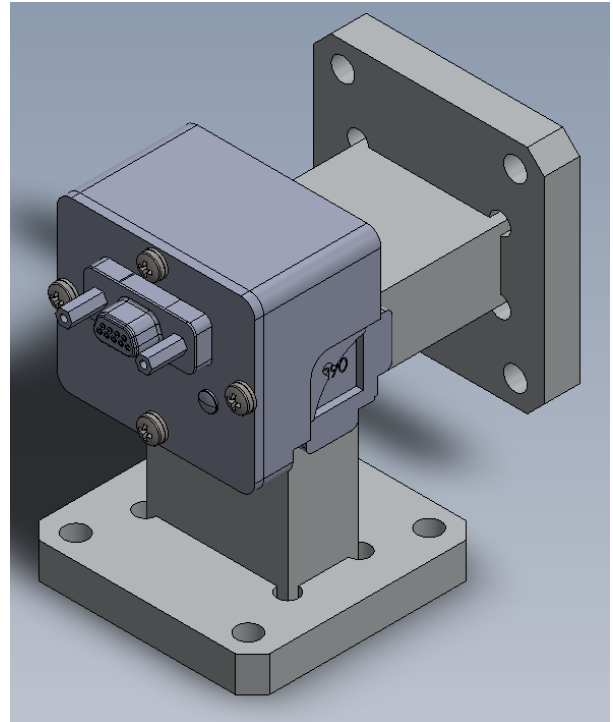

### Product Description

An Arc Detector is used to protect expensive RF power source and high-power waveguide devices from the arcing process, which can occur in waveguide systems. Power breakdown in waveguides can occur as a result of an excessive voltage gradient at some point where there is a discontinuity in the wall surface. A minor imperfection, a junction where the coupling flanges do not meet properly, or improper positioning of tuning elements in waveguide device cavities can all contribute to the problem. In any event, such a breakdown is accompanied by arcing, i.e. an electrical discharge producing visible light, as well as a change in the transmission characteristics of the waveguide which reflects a corresponding change in the loading on the microwave power source. The breakdown may be progressive, with the arc being small at first, then rapidly becoming larger as the air or other gas in the vicinity become ionized. If the resulting load change becomes large enough, the power source will be damaged.

The Arc Detector is an opto-electronic device which detects infrared and visible arcs in high-power waveguide transmission lines. In response to a visible arc in the waveguide facing the detector device, the Arc detector produces a signal (“Alarm”) which may be used to shut down the system.

The Arc Detector can be incorporated into one assembly with other waveguide devices such as waveguide directional couplers, magic tees, circulators, waveguide filters, diplexers, power source’s waveguide launcher, etc.

# WR90 Arc Detector

## Product Specifications

Electrical	
Waveguide Size	WR90
Operating Frequency Range	8.2 - 12.5 GHz
Peak Power	100 kW
Average Power	5 kW
VSWR (typical)	-27 dB max
Insertion Loss	0.05 dB max
Spectral Responsivity	320nm – 1050nm (visible light and near-infrared spectrum)
Electromagnetic Coupling (between waveguide main line and detector's cavity)	> 95 dB
Optical Sensitivity (typical)	Equal in both directions (toward Port 1 or Port 2)
Flange 1 (port 1. INPUT)	COVER, through holes, $\varnothing=4.2\text{mm}$
Flange 2 (port 2, OUTPUT)	COVER, through holes, $\varnothing=4.2\text{mm}$
Output (interface) connector	Circular MIL-DTL-26482 Spec Connector, 6 pin (male), Shell size 10
DC Supply Voltage	Typical +15V (Min=5.7V /Max=20V)
Supply Current	60 mA (max)
Output Voltage	TTL 5V Fault/Fired Alarm (Vo) = 0~0.8Volts, non-latched
Response Time	less than 10 $\mu\text{sec}$
Pressure Sealed to:	30 PSI
Operating Temperature Range	- 40°C + 85°C